



盾安自动化
Dun'an Automation

远传水位液位计使用说明书
Remote water level gauge operation manual

盾安自动化
Dun'an Automation



安徽盾安自动化仪表科技有限公司
Anhui Dun 'an Automation Instrument Technology Co. , Ltd.

远传水位液位计

Remote water level gauge

一、概述

安徽盾安自动化仪表科技有限公司研制的汽包远传水位液位计可实现替代进口产品电容式液位计，在磁质中磁化方向的改变会引起介质晶格间距的改变，从而使得磁质的长度和体积发生改变，即：Magnetostriction 现象，也称为威德曼效应，其逆效应称为维拉里效应。

Magnetostriction 原理是利用两个不同磁场相交时产生一个应变脉冲信号，然后计算这个信号被探测所需的时间周期，从而换算出准确的位置。这两个磁场一个来自磁环中的永磁铁，另一个来自传感器电子仓中的电子部件产生的激励脉冲。激励脉冲沿传感器内用 Magnetostriction 材料制造的波导丝以声速运行。当与磁环中的永磁铁相交时，由于 Magnetostriction 现象，波导丝产生的机械振动形成一个应变脉冲。应变脉冲很快便被电子仓中的感测电路探测到。从产生激励脉冲的一刻到应变脉冲被探测到总的时间乘以固定的声速，我们便能准确的计算出磁铁的位置变化。这个过程是连续不断的，所以每当磁环位置改变时，新的位置会迅速被测量出来。由于输出信号是真正的绝对值，而不是比例的或需要再放大处理的信号，所以不存在信号漂移或变值的情况，更不必像其他传感器那样需要定期重标。

The boiler water level transmitter developed by Anhui Dun'an Automation Instrument Technology Co., Ltd. can replace the imported level gauge. The change of magnetization direction in a magnetic material will cause a change in the spacing of the medium lattice, which in turn causes a change in the length and volume of the magnetic material, i.e.: the magnetostriction phenomenon, also known as the Wiedemann effect, and its inverse effect is called the Villari effect. The magnetostriction principle is to use two different magnetic fields to produce a strain pulse signal when they intersect, and then calculate the time period required for the signal to be detected, as to convert it into an accurate position. One of these magnetic fields comes from the permanent magnet in the magnetic ring, and the other comes from the excitation pulse generated by the electronic in the sensor electronic chamber. The excitation pulse runs at the speed of sound along the waveguide wire made of magnetostrictive material inside the sensor. When it intersects with the permanent magnetic field in the magnetic ring, a strain pulse is formed due to the magnetostriction phenomenon. The strain pulse is soon detected by the sensing circuit in the electronic chamber. From the moment the excitation pulse is generated to the time the strain pulse is detected, the total time multiplied by the fixed sound speed allows us to accurately calculate the change in the position of the magnet. This process is continuous, so whenever the position of the magnetic ring changes, the new position is quickly measured. Since the output signal is a true absolute value, not proportional or signal that needs to be amplified again, there is no signal drift or change, and there is no need to recalibrate regularly like other sensors.

位置测量的工作原理

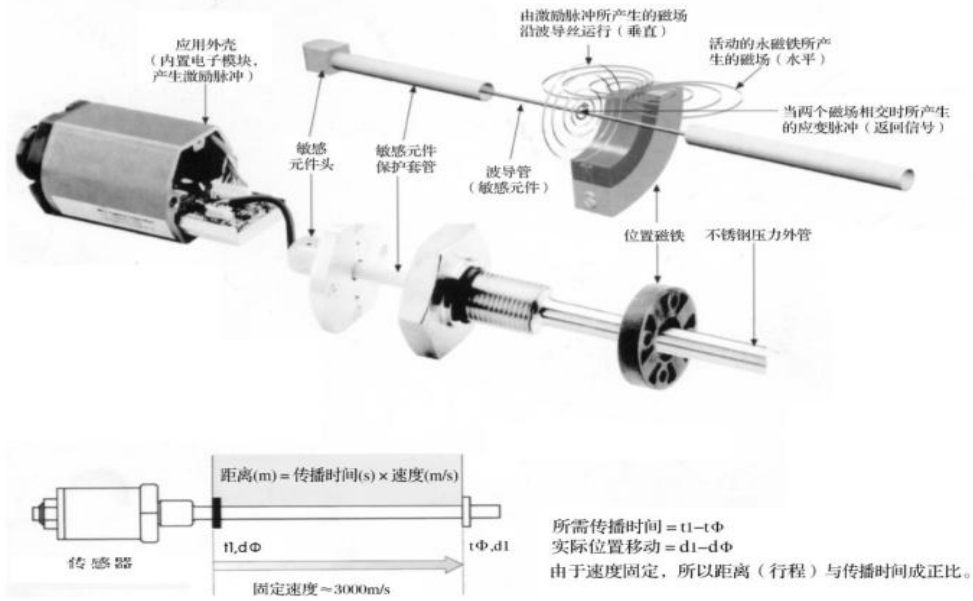

Principle diagram of position measurement

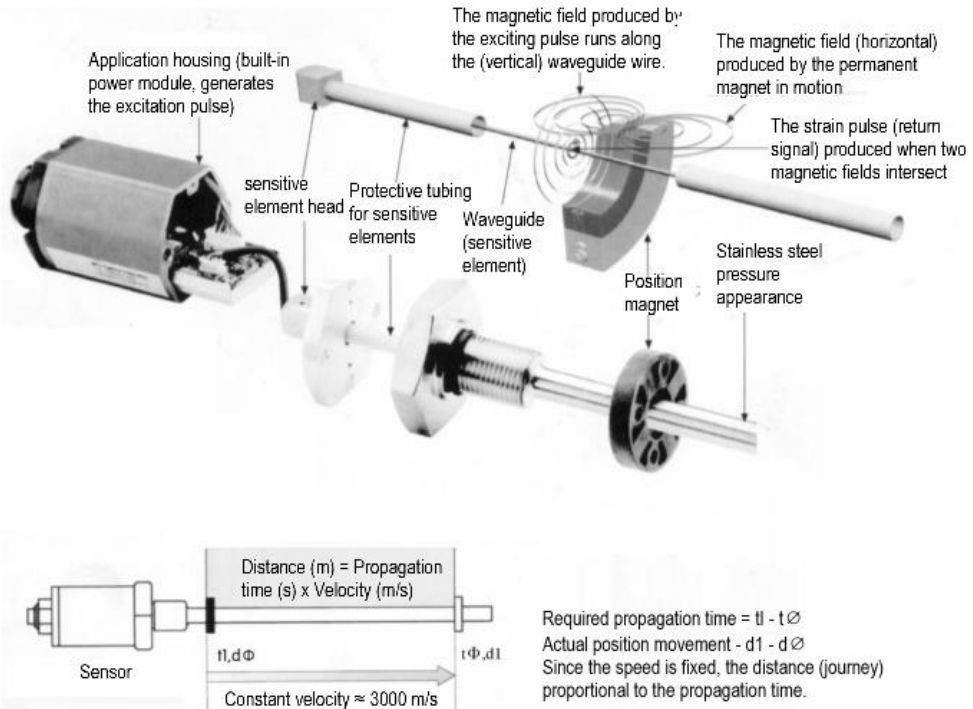

二、传感器简介

传感器为我公司开发的模块组装式液位传感器，它提供高速、可靠和精确的数据处理和通讯。液位传感器提供多种输出模式，包括模拟量的电压和电流，数字量的RS485等。输出信号可以提供多个位置和温度输出。详尽的多功能输出模式，为客户提供了更多的选择。

AT/UAT100系列液位传感器为非接触式，永不磨损。具有高分辨率、高精度、高稳定性、高可靠性、响应时间快、工作寿命长等优点。传感器不用重新标定，也不用定期维护。

液位传感器的防爆产品严格按照GB3836.1-2000《爆炸性气体环境用电气设备 通用要求》、GB3836.2-2000《爆炸性气体环境用电气设备 隔爆型“d”》GB3836.4-2000《爆炸性气体环境用电气设备 本质安全型“i”》的要求研制、设计、制造。并取得国家仪器仪表防爆安全监督检验站颁发的防爆合格证。隔爆标志：EXd II BT6。本质安全标志：EXia II CT6。

液位传感器可广泛应用于：

- ◆工业现场液位测量与控制
- ◆油罐液位测量
- ◆化工过程液位控制
- ◆制药罐液位控制
- ◆食品饮料液罐控制
- ◆大坝水位监控
- ◆饮用水和污水处理等
- ◆汽轮机气阻阀门开度的检测与控制
- ◆水轮机导叶开度的检测与控制
- ◆其它机械定位和位移检测等

2. Introduction to the sensor

The sensor is a modular assembly level sensor developed by our company, which provides high-speed, reliable and precise data processing and communication.

The level sensor provides a variety of output modes, including analog voltage and current, digital RS485, etc. The output signal can multiple position and temperature outputs. The comprehensive multi-functional output mode provides customers with more choices.

The AT/UAT100 series level sensors are non-contact and wear out. They have the advantages of high resolution, high accuracy, high stability, high reliability, fast response time, and long service life. The sensor does not need to be calibrated and does not require regular maintenance.

The explosion-proof products of the level sensor are developed, designed, and manufactured in strict accordance with the requirements of GB336.1-2000 "General Requirements for Electrical Equipment in Explosive Gas Atmospheres", GB3836.2-2000 "Electrical Equipment in Explosive Gas Atmospheres", and GB3836.4-2000 "Intrinsic Safety Electrical Equipment in Explosive Atmospheres". The explosion-proof certificate was issued by the National Instrument and Instrument Explosion-proof Safety Supervision and Inspection Station. The explosion-proof: EXd II BT6. The intrinsic safety mark: EXia II CT6.

The level sensor can be widely used in:

- ◆ Industrial site level measurement and control
- ◆ Oil tank level measurement
- ◆ Chemical process level control
- ◆ Pharmaceutical tank level control
- ◆ Food and beverage tank control
- ◆ Dam water level monitoring
- ◆ Drinking water and sewage treatment, etc.
- ◆ Steam turbine air block valve opening detection and control
- ◆ Water turbine guide vane opening detection and control
- ◆ Other mechanical positioning and displacement detection, etc.

三、主要技术性能指标

- ★ 量程范围 (mm) 80~24000mm
- ★ 非线性误差 $\pm 0.05\%FS$; 200mm 以下最大误差 100 μm
- ★ 重复性误差 $\leq 0.002\%FS$
- ★ 分辨率 $\leq 0.02mm$
- ★ 迟滞 $\leq 0.002\%FS$
- ★ 供电电压: 24VDC
- ★ 输出形式/工作电压
输出信号: 4 ~ 20mADC、4 ~ 20mADC/HART
数字信号: RS485
- ★ 工作温度 $-40\sim+120^{\circ}C$
- ★ 测杆材料 0Cr18Ni9 (304)
316 不锈钢 (特殊定制)
- ★ 电子仓外壳材料 0Cr18Ni9 (304)
- ★ 外壳防护等级 IP65
- ★ Wiring method PWR/COMM (24VDC)
PWR/COMM- (-24VDC)。

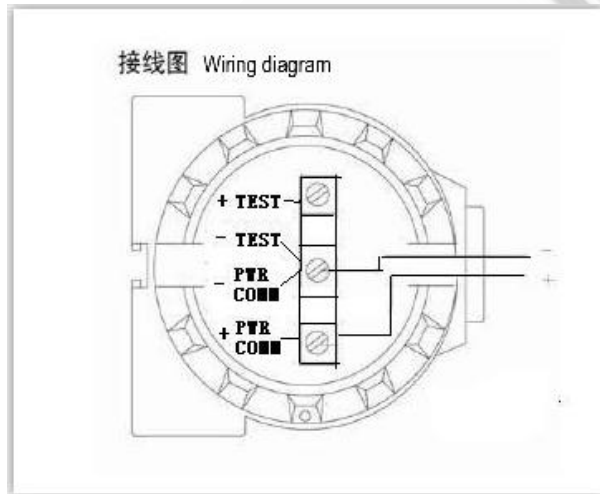

III. Main Technical Performance Indicators

- ★ Range (mm) 80~24000mm
- ★ Nonlinearity Error $\pm 0.05\% FS$; maximum error of 100 μm below 200mm
- ★ Repeatability Error $\leq 0.002\% FS$
- Resolution $\leq 0.02mm$
- ★ Hysteresis $\leq 0.002\% FS$
- ★ Supply Voltage: 24VDC
- ★ Output/Working Voltage
Output Signal: 4 ~ 20mADC, 4 ~ 20mADC/HART
Digital Signal: RS485
Working Temperature $-40\sim 120^{\circ}C$
- ★ Measuring Rod Material 0Cr18Ni9 (304)
31 Stainless Steel (Special Order)
- ★ Electronic Chamber Case Material 0Cr18Ni9 (304)
- ★ Case Protection Grade IP6



四、按键模式说明

远传水位液位计表头上都有三个按键，分别为“M”、“S”、“Z”。也支持外部扩展干簧管接口，实现不开盖调整。此时支持两个按键，分别为“S”、“Z”。

针对这两种应用，本产品支持“双按键”和“三按键”两种操作模式。

“三按键”操作模式：操作更快捷，适用于 LCD 上具备 3 个按键的产品。

Z 键用于进入提示数据设置界面和移位；

S 键用于进入数据设置界面、增加数字和数据保存；

M 键用于数据保存。

注：在三按键模式下，任何时候都可以按下“M”键，保存当前的设置数据。

“双按键”操作模式：这种操作模式通常用于外部只有 2 个非接触按键的情况。

Z 键用于进入提示数据设置界面和移位；

S 键用于进入数据设置界面、增加数字和数据保存。

注：在双按键模式下，输入数据时，必须等左下角的下箭头闪烁时，才能通过按下“Z”键保存设置数据。

4.1. 数据设置方法

现场设置参数分为“直接数字输入”和“菜单选择”两种类型。

4.1.1 “直接数字输入”设置方法

当左下角的“88”字符显示 1~7 时，表明变送器处于现场组态模式，此时可以通过按键输入密码、修改参数、或者进行迁移。

数据设置过程中，“S”键用于调整数字和小数点，“Z”键用于移位，“M”键用于保存。

IV. Key Operation Mode Description

All the remote water level gauges have three keys on the meter head, which are "M", "S", "Z" respectively. It also supports an external expansion of the dry reed switch interface to adjust without opening the cover. At this time, two keys are supported, which are "S", "Z".

For these two applications, this product supports two operation modes: "Double Key" and "Triple Key".

"Triple Key" operation mode: The operation is more convenient and suitable for products with 3 keys on the LCD.

The Z key is used to enter the prompt data setup interface and shift;

The S key is used to enter the data setup interface, increase numbers, and save data;

The M key is used to save data.

Note: In the triple key mode, you can press the "M" key at any time to save the current setup data.

"Double Key" operation mode: This operation mode is usually used when there are only 2 non-contact keys on the outside.

The Z key is used to enter the prompt data setup interface and shift;

The S key is used to enter the data setup interface, increase numbers, and save data.

Note: In the double key mode, when entering data, you must wait for the down arrow in the lower left corner to flash before you can save the setup data by pressing the "Z" key.

4.1. Method of Data Configuration

The field configuration parameters are divided into two types: "Direct Numerical Input" and "Menu Selection".

4.1.1 "Direct Numerical Input" Configuration Method

When the "88" character in the lower left corner displays 1 to 7, it indicates that the transmitter is in the field configuration mode, and at this time, the password can be entered by key, the parameters can be modified, or migration can be performed.

During the data configuration process, the "S" key is used to adjust the numbers and the decimal point, the "Z" key is used to shift, and the "M" key is used to save.

设置过程如下：

1. 按下 S 键进入数据设置界面，同时符号位开始闪烁，表示可修改符号位。
2. 若再次按下 S 键，可以切换数据的正负（正号用上箭头表示）。
3. 按下 Z 键，第一位数字位开始闪烁，表示可修改，此时长按或连续多次按下 S 键，设置数字在 0~9 之间循环。
4. 再次按下 Z 键，可依次设置第二位到第五位数字，设置方法与第一位完全相同。
5. 设置完第五位数字后，按下 Z 键，开始设置小数点。四个小数点同时开始闪烁，表示可以设置小数点，此时按 S 键，小数点位置循环切换。
6. 小数点设置完成后，按下 Z 键，左下箭头开始闪烁，表示可以保存设置。
7. 按下 S 键，保存设置；按下 Z 键，符号位开始闪烁，可重新开始设置数据。

注：若为“三按键”操作模式，在数据设置过程中，任何时刻都可以按下 M 键，以快速保存设置，而不必等到下箭头闪烁时才可以保存设置。

The setting process is as follows:

1. Press the S key to enter the data setting interface, and the symbol bit will start flashing, that the symbol bit can be modified.
 2. If the S key is pressed again, the data can be switched between positive and negative (the positive sign is represented by the arrow).
 3. Press the Z key, and the first digit position will start flashing, indicating that it can be modified. At this time, press and hold the S or press the S key continuously for several times, and the number will cycle between 0~9.
 4. Press the Z key again, and you can set the second fifth digit positions in turn. The setting method is exactly the same as the first position.
 5. After setting the fifth digit, press the Z key to start setting the decimal. The four decimal points will start flashing at the same time, indicating that you can set the decimal point. At this time, press the S key, and the position of the point will cycle.
 6. After setting the decimal point, press the Z key, and the lower left arrow will start flashing, indicating that you can save the settings.
 7. Press the S key to save the settings; press the Z key, and the symbol bit will start flashing, indicating that you can start setting the data again.
- Note: it is a "three-key" operation mode, you can press the M key at any time during the data setting process to quickly save the settings without having to wait until the arrow flashes to save the settings.



下面举例说明设置方法。假设原来的第一浮子量程上限为 100cm，新输入上限为 400cm。

Here is an example of how to set it up. Suppose the original upper limit of the first float range is 100 cm, and the new entered upper limit is 400 cm.

<ul style="list-style-type: none"> ➤ 进入“设置第一浮子量程上限”功能，如右所示。 ➤ Enter the "Set the upper limit of the first float range" function, as shown on the right. 	<p>设置量程下限界面</p> <p>Set the lower limit of the range interface</p> <div style="border: 1px solid black; padding: 5px; text-align: center; width: fit-content; margin: 10px auto;"> ↑ 1 0 0.0 0 4 cm </div> <p>开始设置量程下限界面</p> <p>Enter the lower limit range setting interface</p> <div style="border: 1px solid black; padding: 5px; text-align: center; width: fit-content; margin: 10px auto;"> ↑ 1 0 0.0 0 4 cm </div>
<ul style="list-style-type: none"> ➤ 按下“S”键，进入设置量程下限功能，此时左下角显示的箭头开始闪烁，表示已经进入设置。 ➤ Press the "S" key to enter the function of setting the lower limit of the range, at this time, the arrow displayed in the lower left corner starts to, indicating that it has entered the setting. 	<p>设置负数界面</p> <p>Set negative number interface.</p> <div style="border: 1px solid black; padding: 5px; text-align: center; width: fit-content; margin: 10px auto;"> =0.0 0 0 0 4 cm </div>
<ul style="list-style-type: none"> ➤ 此时按下“S”键，将在“↑”和“—”之间切换。如果显示“—”，表示将输入的是负数（小于0的数据）。 ➤ Press the "S" key at this time to switch between "↑" and "—". If "—" is displayed, it indicates that a negative number data less than 0) will be entered. 	<p>设置最高位界面</p> <p>Set the highest bit interface</p> <div style="border: 1px solid black; padding: 5px; text-align: center; width: fit-content; margin: 10px auto;"> 1 0 0.0 0 4 cm </div>
<ul style="list-style-type: none"> ➤ 此时按下“Z”键，第1个“0”开始闪烁，表示可以输入新的数据。 ➤ Press the "Z" key at this time, the first "0" begins to flash, indicating that new data can be entered. 	<p>设置最高位界面</p> <p>Set the highest bit interface</p> <div style="border: 1px solid black; padding: 5px; text-align: center; width: fit-content; margin: 10px auto;"> 4 0 0.0 0 4 cm </div>

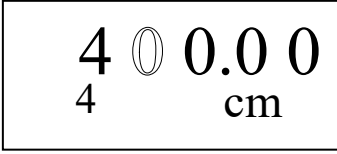
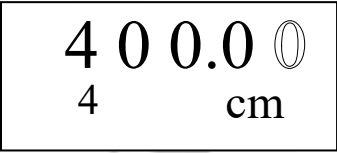
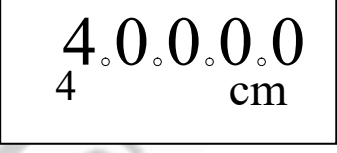
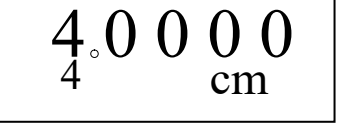
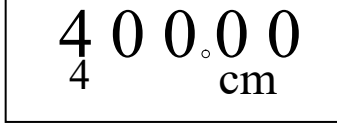
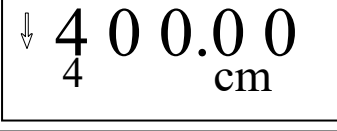
<ul style="list-style-type: none"> ➤ 按下“Z”键，第2个“0”开始闪烁，表示可以输入数据。如果需要修改，则按“S”键输入新的数据。 ➤ Press the "Z" key, the second "0" will start flashing, indicating that data can be entered. If you need to modify, press the "S" key to enter new data. 	<p>设置第2位界面</p> <p>Set the second interface</p> 
<ul style="list-style-type: none"> ➤ 继续按“Z”键，数字从第2到第5位依次闪烁。可以输入需要的数据。 ➤ Keep pressing the "Z" key, the numbers from the 2nd to the 5th will flash in turn. You can enter the required data. 	<p>设置第5位界面</p> <p>Set the 5th interface</p> 
<ul style="list-style-type: none"> ➤ 再次按下“Z”键，小数点全部闪烁，表示可以输入小数点位置。 ➤ Hold down the "Z" key again, all the decimal points flash, indicating that you can enter the position of the decimal point. 	<p>设置小数点位置界面</p> <p>Set decimal point position interface</p> 
<ul style="list-style-type: none"> ➤ 按下“S”键，则最高位的小数点开始闪烁，表示当前设置的小数点位置。 ➤ Pressing the "S" key will cause the decimal point in the most significant position to start flashing, indicating the current position of the decimal point ➤ 继续按“S”键，小数点位置向右移动。到达期望的位置后，按下“Z”键，结束小数点的设置。 ➤ Keep pressing the "S" key to move the decimal point to the right. When you reach the desired position, press the "Z" key to end the setting the decimal point. ➤ 此时左小角的下箭头开始闪烁，表示此时可以按下“S”键，完成当前的数据输入。 ➤ At this time, the down arrow in the lower left corner begins to flash, indicating that the "S" key can be pressed to complete the current data entry 	<p>小数点在最高位</p> <p>The decimal point is in the highest position.</p>  <p>小数点在期望位置</p> <p>The decimal point is in the expected position</p>  <p>小数点设置完成</p> <p>Decimal point setting completed</p> 
<ul style="list-style-type: none"> ➤ 按下“S”键，或者按下“M”键，完成数据输入。并自动转到设置阻尼界面。 ➤ Press the "S" key, or press the "M" key to complete data entry. Automatically switch to the damping setting interface. 	

4.1.2 “菜单选择” 设置方法

- 按下“S”键，进入设置功能，此时右下角显示的选择项开始闪烁，表示可以设置新的选择项。
- 按下“S”键，则依次切换各个选择项。
- 切换到需要的选择项，按下“Z”键，则将保存当前显示的选择项；

五、现场组态功能 5.1.1 组态数据设置

现场使用按键组态时，LCD 左下角“88”字符用于表示当前设置变量类型，也就是当前按键所执行的设置功能。其对应关系为：

4.1.2 "Menu Selection" setting method Press the "S" key to enter the setting function, and the selection item displayed in lower right corner will start flashing, indicating that a new selection item can be set. Press the "S" key to toggle through each selection item in turn. the required selection item is selected, press the "Z" key to save the current displayed selection item; 5. On-site configuration function 5.1.1 data setting When configuring with keys on site, the "88" character in the lower left corner of the LCD is used to indicate the current setting variable type, that, the setting function performed by the current key. The corresponding relationship is as follows:

左下角“88”字符显示 The "88" character in the lower left corner is displayed	设置变量 Set variable	设置方法 Setting method	备注 Note
0 或空 0 or blank	正常显示 Display normally		
1	输入操作码 Enter the operation code 输出***02：可以读写第 2, 3, 4, 5, 9, 10 项； Output***02: can read and write items 2,3,4,5,9,10; 输出***06：可以操作第 6 项； Output***6: can operate item 6; 输出***40：可以读写第 40, 41, 42, 43 项； Output***40: can read and write items 40,41,42,43; 输出***50：可以操作第 50, 51 项； Output***50 can operate items 50,51; 输出***60：可以读写第 60, 61, 62 项； Output***60: can read and write items 60,61,62;	直接数字输入 Direct numerical input	

	输出***70: 可以操作 70 项; Output***70 can operate item 70;		
2	液位单位 Level unit	菜单选择 Menu selection	单位选项: mm, cm, m Unit options: mm, cm, m
3	第一浮子量程下限 Lower limit of the first float range	直接数字输入 Direct numerical input	单位: 液位单位 Unit: level unit
4	第一浮子量程上限 First float range upper limit	直接数字输入 Direct numerical input	单位: 液位单位 Unit: level unit
5	阻尼 damping	直接数字输入 Direct numerical input	单位: 秒 Unit: second 注: 输入“05678”可恢复出厂设置。 Note: Enter "05678" to restore factory settings.
6	任意点迁移 Arbitrary point migration	直接数字输入 Direct numerical input	单位: 液位单位 Unit: level unit
9	第一浮子报警下限 First float alarm lower limit	直接数字输入 Direct numerical input	单位: 液位单位 Unit: level unit
10	第一浮子报警上限 First float alarm upper limit	直接数字输入 Direct numerical input	单位: 液位单位 Unit: level unit
40	第二浮子量程下限 Second float range lower limit	直接数字输入 Direct numerical input	只有设置了“第二浮子”后, 40~43 项的设置才有意义。 Only after the "second float" is set, the settings of items 40 to 43 make sense. 单位: 液位单位 Unit: level unit
41	第二浮子量程上限 Second buoy range upper limit	直接数字输入 Direct numerical input	单位: 液位单位 Unit: level unit
42	第二浮子报警下限 Second float alarm lower limit	直接数字输入 Direct numerical input	单位: 液位单位 Unit: level unit
43	第二浮子报警上限	直接数字输入	单位: 液位单位

	Second float alarm upper limit	Direct numerical input	Unit: level unit
50	下限校准 Lower limit calibration	直接数字输入 Direct numerical input	单位：液位单位。 Unit: level unit 特别说明：在正常显示界面，同时闭合“M”键和“Z”键5秒后，直接进入该项。 Special Note: In the normal display interface, press and hold the "M" key and the "Z" key for 5 seconds to directly enter this item
51	上限校准 Upper limit calibration	直接数字输入 Direct numerical input	单位：液位单位。 Unit: level unit 特别说明：在正常显示界面，同时闭合“M”键和“S”键5秒后，直接进入该项。 Special Note: In the normal display interface, press and hold the "M" key and the "S" key for 5 seconds to directly enter this item
60	杆长，制造专用 Rod length, manufacturing specific	直接数字输入 Direct numerical input	单位：mm Unit: mm
61	底部偏移量，制造专用 Bottom offset, for manufacturing use only	直接数字输入 Direct numerical input	单位：mm Unit: mm
62	底部死区，制造专用 Bottom dead center, manufacturing specific	直接数字输入 Direct numerical input	单位：mm Unit: mm
70	校准第二输出电流 Calibration of second output current	校准方法见 5.3.2 特别说明：若第二浮子状态，选择“未连接”，则第二电流输出无效（0.2mA 或 25mA）。 Calibration method see 5.3.2 Special notes: if the second float is in the disconnected state, the	

	second current output is invalid (02mA or 25mA).
--	--

5.1.2 显示变量设置

液晶显示屏能显示“电流”、“百分比”、“主变量”、“温度”四种变量的一种或交替显示其中的两种（间隔时间4秒）。在实时正常显示状态，使用S键能更改两个显示变量，当两个显示变量设定为相同的参数，屏幕上固定显示一种变量；当两个显示变量设定为不同的参数时，屏幕上交替显示两种变量。

方法如下：按下“S”键，当前显示变量（如：电流）发生变化，循环显示“电流、百分比、主变量、温度”，当所需要的显示变量（如：主变量）出现在屏幕上时，松开“S”键，即实现了将显示变量“电流”改为“主变量”。

例子：

假设当前显示变量为“电流”，需要设置为：交替显示“主变量”和“百分比”。

步骤：

修改第一个显示变量：按下“S”键，液晶循环显示“电流、百分比、主变量”，当显示“主变量”时，松开“S”键，即可。此时，液晶交替显示“主变量”和“电流”。

修改第二个显示变量：当液晶显示“电流”时，按下“S”键，液晶循环显示“电流、百分比、主变量”，当显示“百分比”时，松开“S”键，即设置成功。

5.1.2 Display Variable Settings

The LCD display can show one of the four variables: "Current," "Percent," "Main Variable," "Temperature," or alternate display of two of them (with an interval of 4 seconds). In real-time normal display mode, the S can be used to change the two display variables. When the two display variables are set to the same parameter, one variable is fixedly displayed on the screen; when the two display are set to different parameters, the two variables are alternately displayed on the screen.

The method is as follows: press the "S" key, and the current display variable (e.g., Current) changes, cycling through "Current, Percent, Main Variable, Temperature," and when the required display variable (e.g., Main) appears on the screen, release the "S" key to change the display variable from "Current" to "Main Variable."

Example:

Assuming the current display is "Current," and it needs to be set to: alternate display of "Main Variable" and "Percent."

Steps:

Modify the first display variable press the "S" key, and the LCD cycles through "Current, Percent, Main Variable," and when "Main Variable" is displayed, release the "S", and it is done. At this time, the LCD alternately displays "Main Variable" and "Current."

Modify the second display variable: when the LCD shows "Current," press the "S" key, and the LCD cycles through "Current, Percent, Main Variable," and when "Percent" is displayed, release the "S" key, and the setting is successful.

5.1.3 第二输出电流校准

第二输出电流可以通过按键校准，校准步骤如下：

在操作码输入界面输入***70，进入第二输出电流校准状态，液晶左下角“88”字符显示“70”；

在第二输出电流校准状态，闭合Z键5秒，进入4毫安校准状态，液晶左下角“88”字符显示“71”；

在第二输出电流校准状态，闭合S键5秒，进入20毫安校准状态，液晶左下角“88”字符显示“72”；

在4毫安校准状态或20毫安校准状态时，闭合Z按键，减少输出电流；闭合S按键，增加输出电流；步进为16微安；

在4毫安校准状态或20毫安校准状态时，不闭合任何按键10秒，结束调节，并保存调整值；4毫安调节范围为3.8~4.2毫安，20毫安调节范围为19~21.05毫安。



5.1.3 Second Output Current Calibration

The second output current can be calibrated by keying, and the calibration steps are as follows

Enter ***70 at the operation code input interface, and enter the second output current calibration state, and the "88" character in the lower left corner of the displays "70";

In the second output current calibration state, press the Z key for 5 seconds to enter the 4 mA calibration state, and the "88" character in the lower left corner of the LCD displays "71";

In the second output current calibration state, press the S key for 5 seconds enter the 20 mA calibration state, and the "88" character in the lower left corner of the LCD displays "72";

In the mA calibration state or 20 mA calibration state, press the Z key to reduce the output current; press the S key to increase the output current; the step is 16 μ A;

In the 4 mA calibration state or 20 mA calibration state, do not press any key for 10 seconds to end adjustment and save the adjustment value;

The adjustment range of 4 mA is 3.8~4.2 mA, and the adjustment range of 20A is 19~21.05 mA.

型号命名方法

Type Naming Method

DAUHZ 汽包远传水位液位计		Drum level gauge with remote transmitter	
1 磁致脉冲 2 电容式		1 Magnetic pulse; 2 Capacitive	
信号输出		Signal output	
6 4-20mA+HART			
7 4-20mA			
接线盒形式		Junction box form	
0 普通型 1 防爆型		0 Ordinary type 1 Explosion-proof type	
电气接口			
1 M20x1.5 1 1/2NPT			
测量筒外径		Measure the outer diameter of the measuring cylinder	
50 带测量筒 00 不带测量筒		50 with measuring cylinder; 00 without measuring cylinder	
安装形式		Mounting form	
C 侧装		side-mounted;	
测量范围		Measurement range	
0-6000mm			
其它表示		Other expressions	
K DN50 法兰 flange 0 缆式 Cable-type 1 杆式 rod type 2 M20x1.5			
A -50~200℃ B -40~160℃ C -20~450℃			
C 测量精度±1mm D 测量精度±2mm		Measurement accuracy	
Z 带显示 B 不带显示		Z with display; B without display	
S 反向极性保护功能		Reverse polarity protection function 0 不带 without	
S 防雷击防射频干扰		Lightning protection and radio frequency interference prevention	
EX 防爆		explosion-proof	
DAUHZ 1 6 1 1 50 C 440 KBCZSS EX		典型型号示例 Model Example	

